

SELF-PROPELLED ARTICULATING BOOMS

Z™-45/25 RT & Z™-45/25J RT

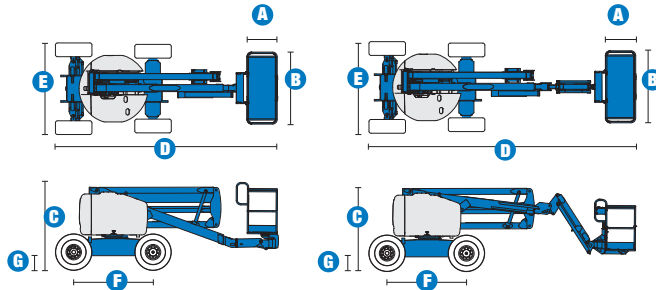

Specifications



MODELS	Z™-45/25 RT		Z™-45/25J RT	
MEASUREMENTS	US	Metric	US	Metric
Working height maximum*	51 ft 11 in	16.00 m	52 ft 2 in	16.07 m
Platform height maximum	45 ft 11 in	14.00 m	46 ft 2 in	14.07 m
Horizontal reach maximum	25 ft	7.62 m	25 ft 1 in	7.65 m
Up and over clearance maximum	23 ft 6 in	7.16 m	23 ft 6 in	7.16 m
A Platform length	2 ft 6 in	.76 m	2 ft 6 in	.76 m
B Platform width	6 ft	1.83 m	6 ft	1.83 m
C Height - stowed	6 ft 11 in	2.11 m	6 ft 11 in	2.11 m
D Length - stowed	18 ft 3 in	5.56 m	22 ft 5 in	6.83 m
E Width	7 ft 6 in	2.29 m	7 ft 6 in	2.29 m
F Wheelbase	6 ft 8 in	2.03 m	6 ft 8 in	2.03 m
G Ground clearance - center	1 ft 3.5 in	.39 m	1 ft 3.5 in	.39 m

PRODUCTIVITY				
Lift capacity	500 lbs	227 kg	500 lbs	227 kg
Platform rotation	180°		160°	
Vertical Jib rotation	—		135°	
Turntable rotation	355° non-continuous		355° non-continuous	
Turntable tailswing	zero		zero	
Drive speed - stowed	5.0 mph	8.0 km/h	5.0 mph	8.0 km/h
Drive speed - raised**	0.61 mph	1.0 km/h	0.61 mph	1.0 km/h
Gradeability - 2WD - stowed***	30%		30%	
Gradeability - 4WD - stowed***	45%		45%	
Turning radius - inside	5 ft 6 in	1.70 m	5 ft 6 in	1.70 m
Turning radius - outside	14 ft 9 in	4.50 m	14 ft 9 in	4.50 m
Controls	12 V DC proportional		12 V DC proportional	
Tires	355/55 D625		355/55 D625	

POWER				
Power source	Ford DSG-423 4 cylinder gas/LPG 75 hp (56 kW) Deutz diesel D2011L03i 3 cylinder diesel 48 hp (35.8 kW) Perkins diesel 404-D22 4 cylinder diesel 51 hp (38 kW)			
Auxiliary power unit	12 V DC		12 V DC	
Hydraulic tank capacity	24 gal	90.8 L	24 gal	90.8 L
Fuel tank capacity	17 gal	64.4 L	17 gal	64.4 L

WEIGHT****				
2WD	13,675 lbs	6,203 kg	14,300 lbs	6,486 kg
4WD	13,875 lbs	6,294 kg	14,500 lbs	6,577 kg

STANDARDS COMPLIANCE

ANSI A92.5, CSA B354.4, EN 280, AS 1418.10

* The metric equivalent of working height adds 2 m to platform height. U.S. adds 6 ft to platform height.

** In lift mode (platform raised), the machine is designed to operate on firm, level surfaces only.

*** Gradeability applies to driving on slopes. See operator's manual for details regarding slope ratings.

**** Weight will vary depending on options and/or country standards.

www.genieindustries.com

RANGE OF MOTION Z™-45/25 RT

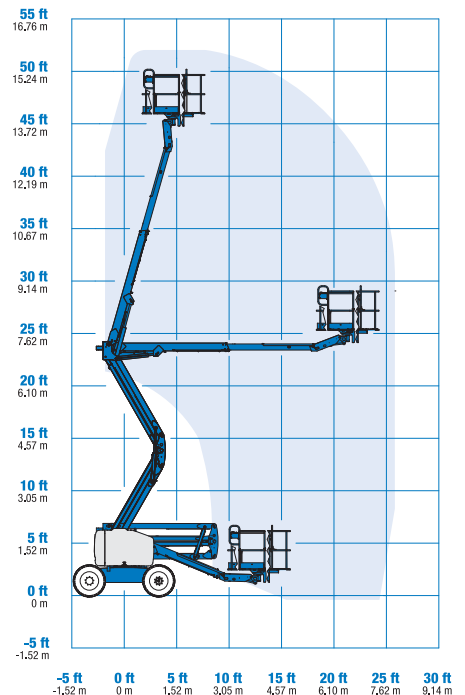

RANGE OF MOTION Z™-45/25J RT

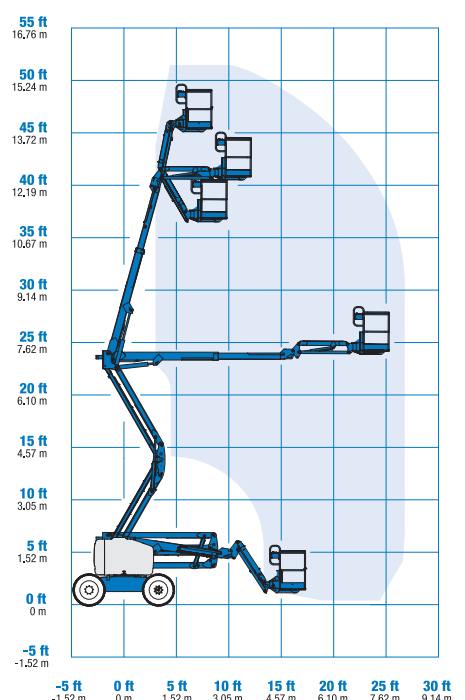

Features

EASILY CONFIGURED TO MEET YOUR NEEDS

PLATFORM OPTIONS

- Steel 6 ft (1.83 m) (standard)
- Steel 6 ft (1.83 m) tri-entry

JIB OPTIONS

- Non-jib
- 5 ft (1.52 m) jib boom

POWER OPTIONS

- Ford gas/LPG 75 hp (56 kW)
- Deutz diesel 48 hp (35.8 kW)
- Perkins diesel 51 hp (38 kW)

DRIVE OPTIONS

- 2WD
- 4WD

AXLE OPTIONS

- Active oscillation (standard on 4WD)
- Non-oscillating

TIRE OPTIONS

- Rough terrain air-filled (standard)
- Rough terrain foam-filled
- Rough terrain non-marking (air or foam-filled)
- High flotation
- Sealant treated air-filled

STANDARD FEATURES

MEASUREMENTS

Z™-45/25 RT

- 51 ft 11 in (16.00 m) working height
- 25 ft (7.62 m) horizontal reach
- 23 ft 6 in (7.16 m) up and over clearance
- Up to 500 lb (227 kg) lift capacity

Z™-45/25J RT

- 52 ft 2 in (16.07 m) working height
- 25 ft 1 in (7.65 m) horizontal reach
- 23 ft 6 in (7.16 m) up and over clearance
- Up to 500 lb (227 kg) lift capacity

PRODUCTIVITY

- Self-leveling platform
- Hydraulic platform rotation
- Fully proportional controls
- Drive enable
- AC power cord to platform
- Horn
- Hour meter
- Tilt alarm
- Descent alarm
- 355° non-continuous turntable rotation
- Positive traction drive
- Two speed wheel motors

POWER

- 12 V DC auxiliary power
- Engine protection package
- Deutz intake air heater
- Swing out engine tray



OPTIONS & ACCESSORIES

PRODUCTIVITY

- Platform swing gate
- Half mesh platform inserts with swing gate
- Platform top auxiliary rail
- Air line to platform
- Thumb rocker steer
- Fire resistant hydraulic oil
- Biodegradable hydraulic oil
- Aircraft protection package*
- Hostile environment package
- Tool tray
- Fluorescent tube caddy
- Pipe cradle (pair)
- Alarm package
- Panel cradle package
- Platform work lights
- Lockable platform control box cover
- Tow package

POWER

- Engine gauge package
- AC generator packages (110V/60Hz - 220V/50Hz, 2200W)
- Cold Weather Packages
- Diesel scrubber/spark arrestor muffler (catalytic muffler)
- LPG tank 33.5 lb (15.19 kg) capacity

* Reduces platform capacity to 440 lbs (only available on jib models)

Genie United States

18340 NE 76th Street
P.O. Box 97030
Redmond, Washington 98073-9730

Telephone **+1 (425) 881-1800**
Toll Free in USA/Canada **+1 (800) 536-1800**
Fax +1 (425) 883-3475

Genie Europe

The Maltings
Wharf Road
Grantham NG31 6BH
UK

Telephone **+44 (0)1476 584333**
Fax +44 (0)1476 584334

Email: AWP-InfoEurope@terex.com

Distributed By:

Effective Date: January, 2010. Product specifications and prices are subject to change without notice or obligation. The photographs and/or drawings in this document are for illustrative purposes only. Refer to the appropriate Operator's Manual for instructions on the proper use of this equipment. Failure to follow the appropriate Operator's Manual when using our equipment or to otherwise act irresponsibly may result in serious injury or death. The only warranty applicable to our equipment is the standard written warranty applicable to the particular product and sale and we make no other warranty, express or implied. Products and services listed may be trademarks, service marks or trade-names of Terex Corporation, Genie Industries, Inc. and/or their subsidiaries in the U.S.A. and many other countries and all rights are reserved. Terex is a Registered Trademark of Terex Corporation in the U.S.A. and many other countries. Genie is a Registered Trademark of Genie Industries, Inc. in the U.S.A. and many other countries. Genie is a Terex Company. © 2010 Terex Corporation.